

PLAS-TIES

**TIE-MATIC
OPERATING MANUAL
FOR
603, 604, 608 MACHINES**



14272 Chambers Road
Tustin, CA 92780
TOLL-FREE: (800) 854-0137
PHONE: (714) 542-4487
FAX: (714) 972-2978

Table of Contents

PAGE	
Section I: General Information	
Supplies and Service.....	4
Introduction.....	5
Warranty.....	5-6
Section II: Specifications	
Model Designation.....	7
603, 604, 608 Specifications.....	7
Performance.....	7
Power Requirements	7
Dimensions	7
Section III: Operation	
Mounting and Start -Up.....	8
Loading Material.....	9-10
Unloading Material	10
Functional Information for the Tie Matic Machine.....	11
Section IV: Maintenance	
General	12
Lubrication	12-13
Section V: Adjustments	
Material Feed Idler.....	13
Section VI: Troubleshooting	
Troubleshooting.....	14-15
Section VII: Parts List	
Parts List.....	16-20
Appendix A: Case & Cover.....	21
Appendix B: Parts Explosion.....	22

SECTION I: General Information

SUPPLIES AND SERVICE

PLAS-TIES twist tie material and service should be ordered from your dealer, distributor, or:

PLAS-TIES

14272 Chambers Road

Tustin, CA 92780

Telephone: (714) 542-4487

(800) 854-0137

Fax: (714) 972-2978

Email: info@plasties.com

When ordering, please provide the following:

1. Part Name or description
2. Part Number and description
3. Number of cycles on Counter
4. Model Number and Serial Number (use Name Plate)
5. Tie Material in use



INTRODUCTION

The operating procedures outlined in this manual are prepared to facilitate the Tie-Matic twist tying machine.

CAUTION:

DO NOT ATTEMPT TO OPERATE YOUR TIE-MATIC BEFORE READING THE OPERATING INSTRUCTIONS.

The efficiency and convenience of the Tie-Matic equipment reduces costly labor hours, while increasing output of securely tied products. Semi-automatic operation delivers up to 40 tied bags or bundles per minute with minimal effort. Insert the bundle at the throat to trigger the tying mechanism and get a twist-tie. All bundles and bags are secured with 2-1/2 full twists of tie material.

WARRANTY

Purchaser acknowledges that there are no warranties, expressed or implied, made by **PLAS-TIES**, its distributors or sales representatives related to the Tie-Matic except the manufacturer's warranty against defective materials and workmanship as follows:

PLAS-TIES warrants the Tie-Matic to be free from defects in materials and workmanship at time of delivery. Liability under this warranty is limited to the repair or exchange of any defective part or parts of the unit providing the same is returned to **PLAS-TIES**, transportation prepaid, within 180 days or 300,000 ties. **THE WARRANTY BEGINS FROM THE DATE OF INSTALLATION AT CUSTOMER SITE AND NOT DATE OF PURCHASE. IN ORDER TO ACTIVATE THE WARRANTY, THE NAME, CITY/STATE, AND SERIAL NUMBER MUST BE CALLED INTO PLAS-TIES' CUSTOMER SERVICE DEPARTMENT. FAILURE TO DO SO WILL RESULT IN LIMITATION OF THE FULL WARRANTY. THIS IS TO INSURE TOTAL QUALITY ASSURANCE AND 800 TOLL FREE TECHNICAL SUPPORT.**

Warranty (continued)

The warranty is void on any Tie-Matic that has been subject to negligence, accident, misuse, failure to use the equipment as instructed in the manual, or that has been tampered with. Cutting the lock wire will void warranty.

This warranty is void if the Tie-Matic is used with anything other than genuine **PLAS-TIES** twist-tie material.

IMPORTANT: If your Tie-Matic® does not operate properly, please bring it to the attention of **PLAS-TIES**, or the dealer or distributor from whom it was purchased. If repairs are needed, the dealer, distributor or other representative of **PLAS-TIES** will arrange to repair or replace parts within the terms of the warranty.

Warranty coverage is limited to the Continental US, Alaska, Hawaii, Puerto Rico, and Canada.

SECTION II: Specifications

MODEL DESIGNATION

This manual covers all models of the Tie-Matic Mark XV. The models are identical in their operation.

Mark XV Models 603, 604 and 608 are equipped with a 2 amp circuit breaker for overload protection .U.L. and approved for the United States.

SPECIFICATIONS

603- Maximum Diameter Capacity - 3/8"

604- Maximum Diameter Capacity - 5/8"

608- Maximum Diameter Capacity - 7/8"

PERFORMANCE

40 ties per minute

2-1/2 full twists on product tied

POWER REQUIREMENTS:

115 Volts A.C.

2.0 Amp circuit breaker

60 cycle

Option available: 50 cycle,

DIMENSIONS/WEIGHT:

Length: 22-1/2"

Height: 10-3/4"

Width at top: 5-1/2"

Width at front feet: 9-1/2"

Weight: 14.8 pounds / 19 pounds with shipping container (no spools)

SECTION III: Operation

MOUNTING AND START-UP

The Tie-Matic should be secured to your work table by:

1. Installing the front stabilizer on the unit. (Figure III-1)
2. Rubber suction cup feet (optional part #16827) are available for complete stability on a stainless steel table or flat surface area.
3. Also for a permanent position, you can bolt the Tie-Matic to a work table with 10-32 screws to the bottom of the unit.
4. The Tie-Matic must be set in the “HOME” position to start the twist-tying process. To set the “HOME” position, align the orange mark on the switch cam with the orange mark on the safety cover. (Figure III-3)
5. To start the machine, plug the machine into a power source and flip the “ON/OFF” switch on the side of the machine.

Front Stabilizer



(Figure III-1)

Suction Cup Feet



(Figure III-2)



(Figure III-3)

SECTION III: Operation

LOADING MATERIAL (MODELS 603, 604, 608)

1. Turn OFF machine before loading material.
2. Hold spool of material with label facing Right-hand palm as shown in (Figure III-4).
3. Once the spool is placed on the spindle, the leading end of the material will feed off the top of the spool heading toward the spool brake arm at the rear of the machine (Figure III-5). Feed material under small roller on brake arm, over top of roller and through no-back clip located at the rear of the machine (Figure III-6). The flat side of material should be facing toward the inside of the machine. (see label inside Tie-Matic cover)
4. Pull about 6-8" of material through the no-back clip (Figure III-7). The end of the material will now be fed through pinion support marked with bright orange to indicate entry.
5. Pull out idler wheel to allow material to pass into the pinion support (Figure III-8).
6. Feed material up to cut-off area just behind cutters.
7. Turn ON the switch located on the side.
8. Cycle the machine and remove any missed ties with caution. If necessary, use needle-nose pliers to remove excess ties.
9. Machine is now ready to operate. If machine is loaded properly, flat side of material will be against your product, creating a tight, secure tie. As shown on the back of the cover label.
10. Ribbon length as required per machine:

Model Ribbon Length:

603 = 3 -11/16" long

604 = 4" long

608 = 4 -7/8" long

SECTION III: Operation

LOADING MATERIAL (MODELS 603, 604, 608)



(Figure III-4)



(Figure III-5)



(Figure III-6)

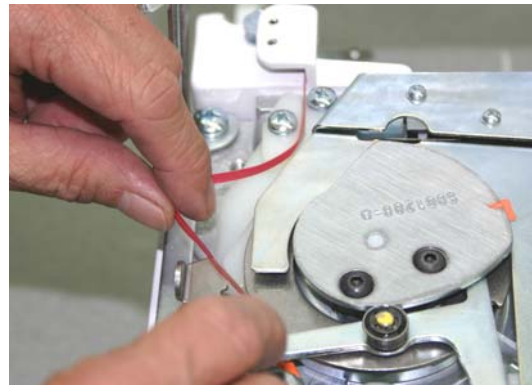

(Figure III-7)

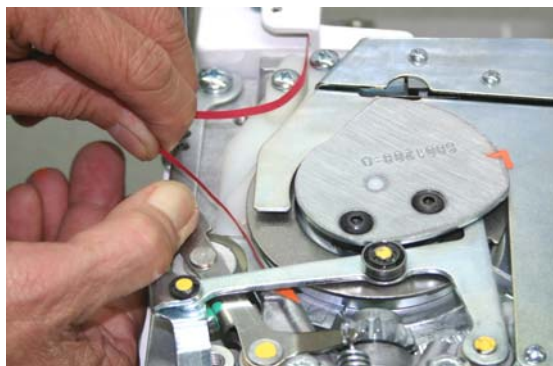

(Figure III-8)

UNLOADING MATERIAL

Turn OFF the machine before unloading material or to change spools. It is necessary to depress the “no-back” before removing material from machine (See Figure III-9). Material must be removed from the rear of the machine.

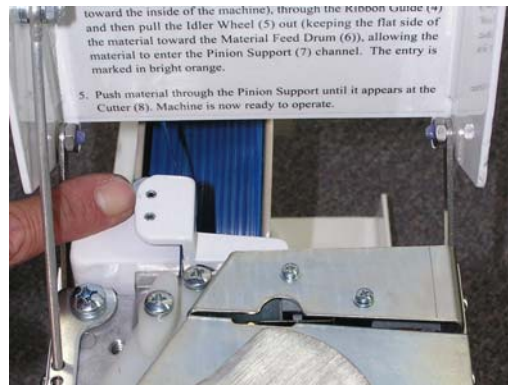

(Figure III-9)

SECTION III: Operation

FUNCTIONAL INFORMATION FOR THE TIE-MATIC MACHINE

HOW IT WORKS:

When a product is inserted into the throat of the machine, it depresses a trigger which trips a limit switch, starting the drive gear motor. The gear motor causes the gear segment to operate through one revolution. This one revolution feeds tie material, wraps it around the product, cuts material to required length and twists ends together.

The product has now been tied and is removed by pulling toward the operator. The Tie-Matic will repeat tying cycle **ONLY** after tied product is removed and another product inserted into the throat.

CLEARING A JAM:

As a safety precaution, the power switch should **ALWAYS** be turned to the OFF position when inspecting the mechanism for any reason, such as: unloading or reloading twist tie material, cleaning the machine, removing material or performing adjustments.

When material jams the twist-tying cycle, you will need to depress the Release Actuator (Appendix A, Item #185) to unlock the motor brake and remove the jammed material (See Figure III-10).

The Tie-Matic must be set in the “HOME” position to start the twist-tying process. To set the “HOME” position, align the orange mark on the switch cam with the orange mark on the safety cover. (Figure III-3)

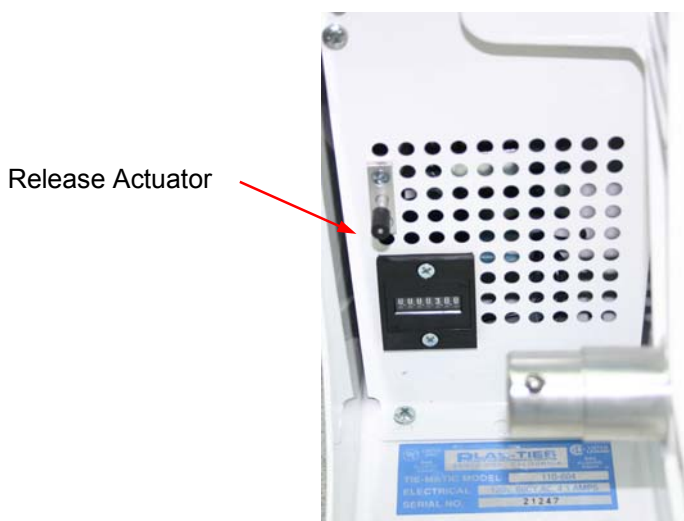

(Figure III-10)

SECTION IV: Maintenance

GENERAL

The Tie-Matic machine is designed for simple operation and, with reasonable care and maintenance, will provide long service.

LUBRICATION

1. Turn OFF the machine
2. Air hose the dust from the machine
3. Lubricate the machine with 1 to 2 drops of 3-in-one multi-purpose oil every 50,000 ties. Apply to areas marked with yellow dots or Θ as shown in Figure IV-1 (8 locations).
4. Lubricate the gear segment (Item #420 of Appendix B) with food machinery lubricant (Bel Ray).

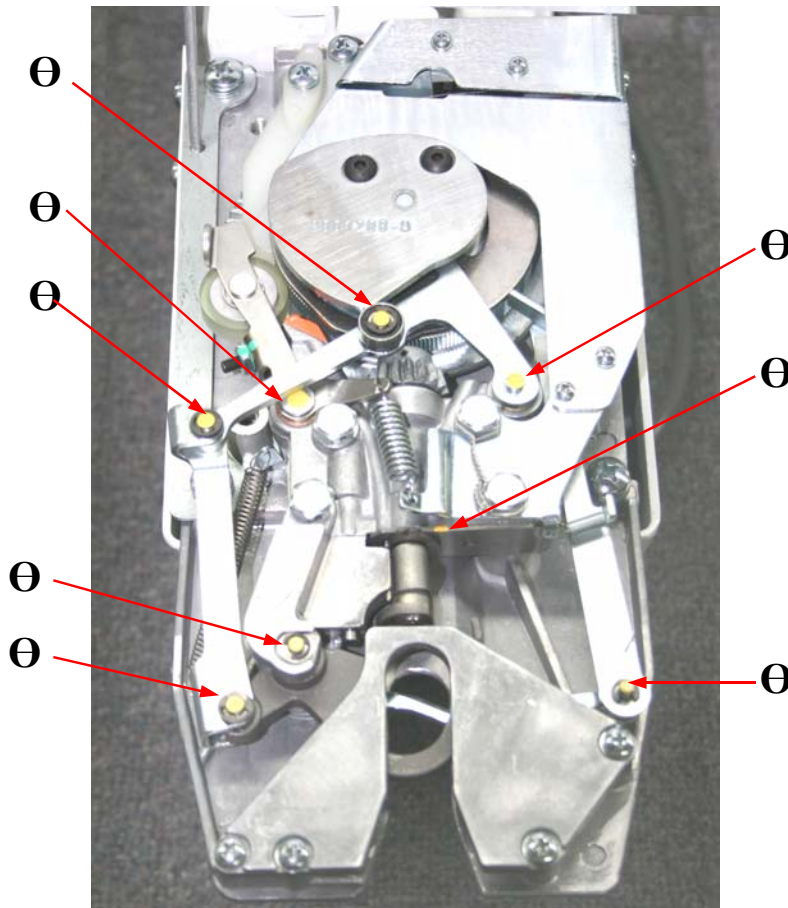

(Figure IV-1)

SECTION IV: Maintenance

CAUTION:

DO NOT OVER-OIL OR OVER-LUBRICATE MACHINE

It is important that the material feed drum and idler pressure wheel be kept free of lubricants. Excess lubrication to the drum (Item #425 of Appendix B) will result in an improper tie due to material slippage, requiring a thorough cleaning of the material feed drum and idler wheel before reuse. Excess oil lubrication could damage the motor.

SECTION V: Adjustments

MATERIAL FEED IDLER (APPENDIX B, ITEM #195)

In the event that the length dimension is out of specification and adjustment is required, perform the following:

1. Cycle the machine to measure the tie length (see page 10, Ribbon Length Per Model)
2. If out of specification, loosen adjusting screw nut (Part # P001070) - Marked with Green or ▲ on Figure IV-2)
3. To increase the length of the tie, turn the set screw (Part # P001230) counter-clockwise. Turning clockwise will shorten the tie length. Adjust as necessary.
4. To keep the settings, secure the screw nut.



(Figure IV-2)

SECTION VI: Troubleshooting

<u>Condition</u>	<u>Cause</u>	<u>Correction</u>
A. Machine jammed	<ul style="list-style-type: none"> a. Using non-Plas-Ties material b. Improper threading of material c. Oversized bundle to be tied d. Material jammed at throat of machine 	<ul style="list-style-type: none"> a. Use Plas-Ties material only b. Check spool & ribbon threading c. Do not exceed capacity diameter of the machine d. Press Release Actuator (Appendix A, Item #185) to allow the motor to rotate, then remove the jammed material.
B. Machine circuit breaker trips	<ul style="list-style-type: none"> a. Motor locked due to jamming 	<ul style="list-style-type: none"> a. Press circuit breaker (#80 on Appendix A) and remove material causing the jam
C. Material end crushed	<ul style="list-style-type: none"> a. Cutters dull or worn out b. Improperly installed movable cutter 	<ul style="list-style-type: none"> a. Replace worn cutter b. Install properly
D. Machine won't start	<ul style="list-style-type: none"> a. Power cord not connected b. Circuit breaker tripped c. Motor malfunction d. Machine switched off 	<ul style="list-style-type: none"> a. Connect to outlet b. Reset circuit breaker c. Replace motor d. Check ON/OFF switch
E. Missing Ties	<ul style="list-style-type: none"> a. Loosely wound ribbon on spool b. Oil or grease on material or feed drum c. Defective spool brake spring d. Improper tie length e. Pinion channel obstructed f. Package too big 	<ul style="list-style-type: none"> a. Rethread material taut b. Clean material feed drum c. Replace spring d. Adjust idle lever e. Clean channel f. Use larger model of machine

SECTION VI: Troubleshooting

<u>Condition</u>	<u>Cause</u>	<u>Correction</u>
F. Tie length short	<ul style="list-style-type: none"> a. Oil or grease on material feed drum b. Improper adjustment of idler lever stop c. Brake arm binding d. Material snag in spool 	<ul style="list-style-type: none"> a. Clean with appropriate solvent b. Adjust stop (See Adjustments V) c. Check material alignment on spool d. Take out snag and re-thread
G. Machine won't stop at end of cycle	<ul style="list-style-type: none"> a. Defective limit switch b. Switch activating cam spring defective c. Defective motor 	<ul style="list-style-type: none"> a. Replace switch b. Replace spring c. Replace motor
H. Machine not working	<ul style="list-style-type: none"> a. Switch Actuating cam is not at HOME position b. Material jammed at pinion support 	<ul style="list-style-type: none"> a. Align the orange dot on the cam with the orange dot on the pinion to start the machine at "HOME" position. b. Clean jammed material

SECTION VII: Parts List

Item No.	New Part No.	Old Part No.	Description	Qty
5	P001270	16408	Screw - Pan Head Phillips 8-32 x .500	2
10	P001200	16400	Screw - Pan Head Phillips 8-32 x .625	1
15	A301140		Cover / Label - Assembly (603)	1
	A301141		Cover / Label - Assembly (604)	1
	A301142		Cover / Label - Assembly (608)	1
20	P001430	16600	Washer - Flat No. 8	1
25	P001430	16600	Washer - Flat No. 8	1
30	P001530	16900	Spacer - Cover	1
35	M001060	117280	Stop - Cover	1
40	P001330	16415	Screw - Pan Head Phillips .250-20 x 1.0	2
45	P001450	16602	Lockwasher - Internal Tooth .250	2
50	S001030	117281	Guide - Cover	1
55	P001560	16906	Switch - On / Off	1
	P001650	16985	On / Off Plate	1
60	M001240	221142-1	Case	1
65	A101040		Foot Stabilizer - Assembly	1
70	P001290	16411	Screw - Pan Head Phillips 10-32 x .500	2
75	P001540	16901	Foot - Rubber	3
	P001210	16401	Screw -Type F, Pan Head Phillips 10-32 x .500	3
80	A301010		Power Cord - Assembly	1
	P001320	16414	Screw - Pan Head 10-32 x .250	1
	P001480	16609	Lockwasher - Internal Tooth No. 10	1
85	P001280	16409	Screw - Pan Head Phillips 10-32 x .313	4
	P001480	16609	Lockwasher - Internal Tooth No. 10	4
90	P001580	16908	Circuit Breaker - 115v 2 amp	1
	P001880		Lockwasher - Internal Tooth .375	1
	A301160		5" Wire - Assembly	1
95	P001080	16103	Nut - Hex .250-20	2
100	P001450	16602	Lockwasher - Internal Tooth .250	2
105	P001060	16101	Nut - Lock 8-32	1
110	P001430	16600	Washer - Flat No. 8	1

SECTION VII: Parts List

Item No.	New Part No.	Old Part No	Description	Qty
115	S001180	221143-1/-2	Hinge - Support Bracket (Left & Right)	1
120	P001450	16602	Lockwasher - Internal Tooth .250	2
125	M001130	117492	Nut - Hinge Cover	2
130	P001470	16608	Lockwasher - Internal Tooth No. 8	2
135	P001330	16415	Screw - Pan Head Phillips .250 x 1.0	2
140	P001920	16619	Washer - Nylon No. 8	2
145	S001220	221303-3	Divider - Case	1
150	P001480	16609	Lockwasher - Internal Tooth No. 10	4
155	P001320	16414	Screw - Pan Head 10-32 x .250	4
160	P001940		Screw - Flat Head Phillips 6-32 x .188	2
165	A301020		Counter - Assembly	1
170	P001630	16960	Screw - Flat Head 4-40 x .375	2
175	M001040	16618	Seal - Counter	1
180	P001640	16961	Nut - Hex 4-40	2
185	A301170		Release - Actuator Switch - Assembly	1
190	M001270	220817	Pin - Idler Lever	1
195	A301060		Lever - Tape Feed Idler - Assembly	1
200	M001460	117494-1	Spring - Tension Material Feed	1
205	P001340	16416	Screw - Pan Head Phillips .250-20 x 1.250	4
210	P001450	16602	Lockwasher - Internal Tooth .250	4
215	A301080		Idler Lever Plate - Assembly	1
220	P001520	16704	Spring Link - Switch Actuating	1
225	P001140	16300	E- Ring	1
230	S001100	117806	Link - Switch Actuating	1
235			Delete	
240	P001190	16305	E- Ring	1
245	P001500	16616	Curved Spring Washer No. 10	1
250	S001230	221194-1	Link - Needle Operating	1
255	M001260	220815	Pin - Idler Wheel	1

SECTION VII: Parts List

Item No.	New Part No.	Old Part No	Description	Qty
260	A301050	220807-1	Needle - Assembly (603)	1
	A301051	117827-1	Needle - Assembly (604)	1
	A301052	320843-1	Needle - Assembly (608)	1
265	P001170	16303	Crescent External Ring	1
270	M001080	117491	Pin - Clevis	1
275	M001220	220866	Sleeve	1
280	P001140	16300	E- Ring	1
	A201030		Master Pinion Support - Assembly (603)	1
	A201031		Master Pinion Support - Assembly (604)	1
	A201032		Master Pinion Support - Assembly (608)	1
	A301120		. Pinion Support - Assembly	1
285	A401030	220814	. Pinion - Assembly	1
290	A301100	220835-2	Trigger Lever - Assembly	1
295	M001230	221145	Spring - Trigger Return	1
300	S001070	221310-1	Shim .005	A/R
	S001080	221310-2	Shim .010	A/R
305	P001160	16302	Crescent External Ring	1
310	P001160	16302	Crescent External Ring	1
315	P001730	56955	Shim - Pinion Support	1
320	M001340	220836	Cover - Trigger (603)	1
	M001600	117829	Cover - Trigger (604)	1
	M001610	320842	Cover - Trigger (608)	1
325	P001470	16608	Lockwasher - Internal Tooth No. 8	4
330	P001220	16402	Screw - Pan Head Phillips 8-32 x .375	4
335	A301090	220859-1	Pinion / Shaft - Assembly	1
340	A301110	117913-1	Needle Actuating - Assembly	1
345	M001020	220943	Guide - Tape Feed	1
	S001050	117409	Shim - Material Guide	A/R
350	P001480	16609	Lockwasher - Internal Tooth No. 10	2
355	P001300	16412	Screw - Pan Head Phillips 10-32 x .750	2

SECTION VII: Parts List

Item No.	New Part No.	Old Part No	Description	Qty
360	P001380	16420	Screw - Pan Head Phillips, 4-40 x .313	1
365	P001250	16405	Screw - Pan Head Phillips 4-40 x .250	1
370	P001720	56954	Shim - Gear Segment	A/R
375	P001980	16402	Screw - Pan Head Phillips 8-32 x .313	4
380	P001470	16608	Lockwasher - Internal Tooth No. 8	4
385	P001740	117914	Motor - Gear	1
390	S001170	220871	Plate - Motor Mount	1
395	P001310	16413	Screw - Flat Head Phillips .250-20 x .375	4
400	P001450	16602	Lockwasher - Internal Tooth .250	4
405	P001150	16301	E- Ring Bowed	1
410	P001720	56954	Shim - Frame	A/R
415	A401100		Gear Support Frame - Assembly (603)	1
	A401101		Gear Support Frame - Assembly (604)	1
	A401102		Gear Support Frame - Assembly (608)	1
	M001350	220845	. Frame - Gear Support (603)	1
	M001580	117832	. Frame - Gear Support (604)	1
	M001590	320845	. Frame - Gear Support (608)	1
	P001030	16003	. Bearing - Radial Ball	2
	P001550	16902	. Groument	1
	A401120		Master Gear Segment - Assembly	1
420	A501030	117596	Gear Segment - Assembly	1
425	S001140	117802	Drum - Material Feed (603)	1
	S001240	117826	Drum - Material Feed (604)	1
	S001250	320844	Drum - Material Feed (608)	1
430	P001460	16607	Lockwasher - Internal Tooth No. 4	2
435	S001150	117801	Guard - Cam Return Spring	1
440	P001250	16405	Screw - Pan Head Phillips 4-40 x .250	2
445	P001390		Screw - Flat Head Phillips with Undercut Head 4-40 x .313	1
450	A401020		Micro-Switch— Assembly	1

SECTION VII: Parts List

Item No.	New Part No.	Old Part No	Description	Qty
455	P001600	16911	Spring - Cam Return	1
460	S001015	220936	Switch Cam - Assembly	1
465	S001210	117585	Cam - Laminate	3
470	M001140	117800	Bearing - Thrust	1
475	S001200	117499	Cam - Needle	1
480	P001370	16419	Screw - Button Head Cap 10-32 x .625	2
485	P001260	16407	Screw - Pan Head Phillips 4-40 x .875	2
490	P001460	16607	Lockwasher - Internal Tooth No. 4	2
495	S001120	117810	Cover - Switch	1
500	M001050	117278	Insulator - Switch	1
505	M001200	220847-2	Spacer - Switch	1
510	S001110	117809	Cover - Safety	1
515	A301150		Brake Arm Spool Assembly	1
520	P001290	16411	Screw - Pan Head Phillips 10-32 x .500	2
525	P001480	16609	Lockwasher - Internal Tooth No. 10	2
530	A301130	220940	Spindle Assembly	1
535	A101030	117489	Brake - Assembly	1
	M001100	117476	. Beam - Brake	1
	M001540	117479	. Spring - No Back	1
	M001550	117480	. Spring - Brake Arm	1
	P001130	16203	. Roll Spring Pin .125 x .563	2
	P001350	16417	. Shoulder - Bolt .375-16	1
	P001360	16418	. Hex Bolt .250-20 x .500	1
	P001490	16615	. Washer - Nylon .250-20	1
	S001040	117295	. No-Back	1
540	M001380	220821	Plate - Stationary Cutter	1
545	M001370	220820	Cutter - Movable (603 & 604)	1
	M001620	320847	Cutter - Movable (608)	1
550	M001190	220833	Cover - Spring	1
555	M001330	117498	Twister - Ribbon	1
560	S001060	117823	Deflector - Material	1
565	P001180	16304	Basic Internal Ring	1
570	M001150	220832	Spring - Cutter	1
575	M001180	220838	Pin - Locating Cutter	1
580	M021960		Bracket - Micro Switch	1
585	P001260	16407	Screw - Pan Head Phillips 4-40 x .875	2
590	P001460	16607	Lockwasher - Internal Tooth No. 4	2
595	M001050	117278	Insulator - Switch	1
600	A401020		Micro Switch - Assembly	1

Appendix A Case & Cover

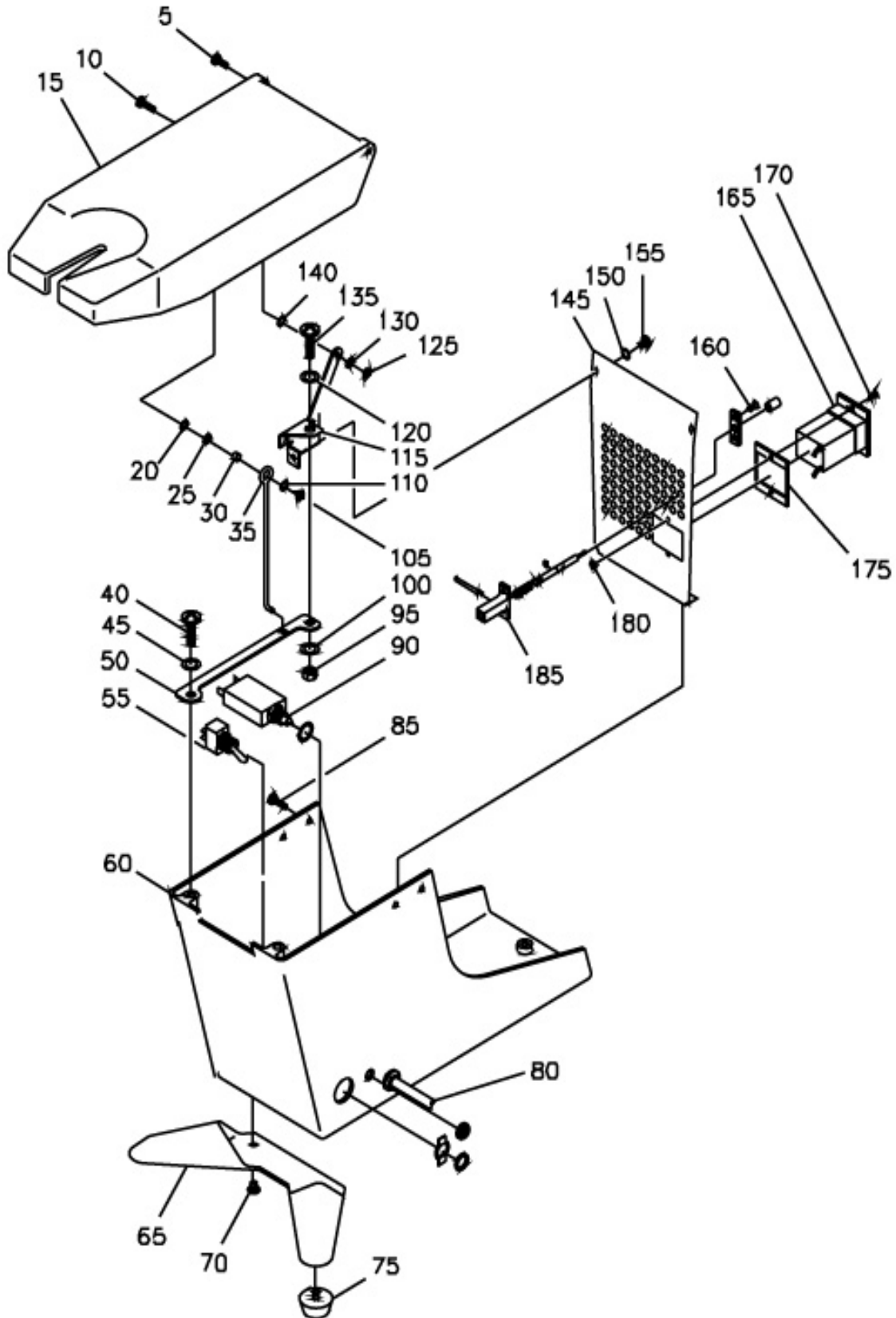

Appendix B Parts Explosion

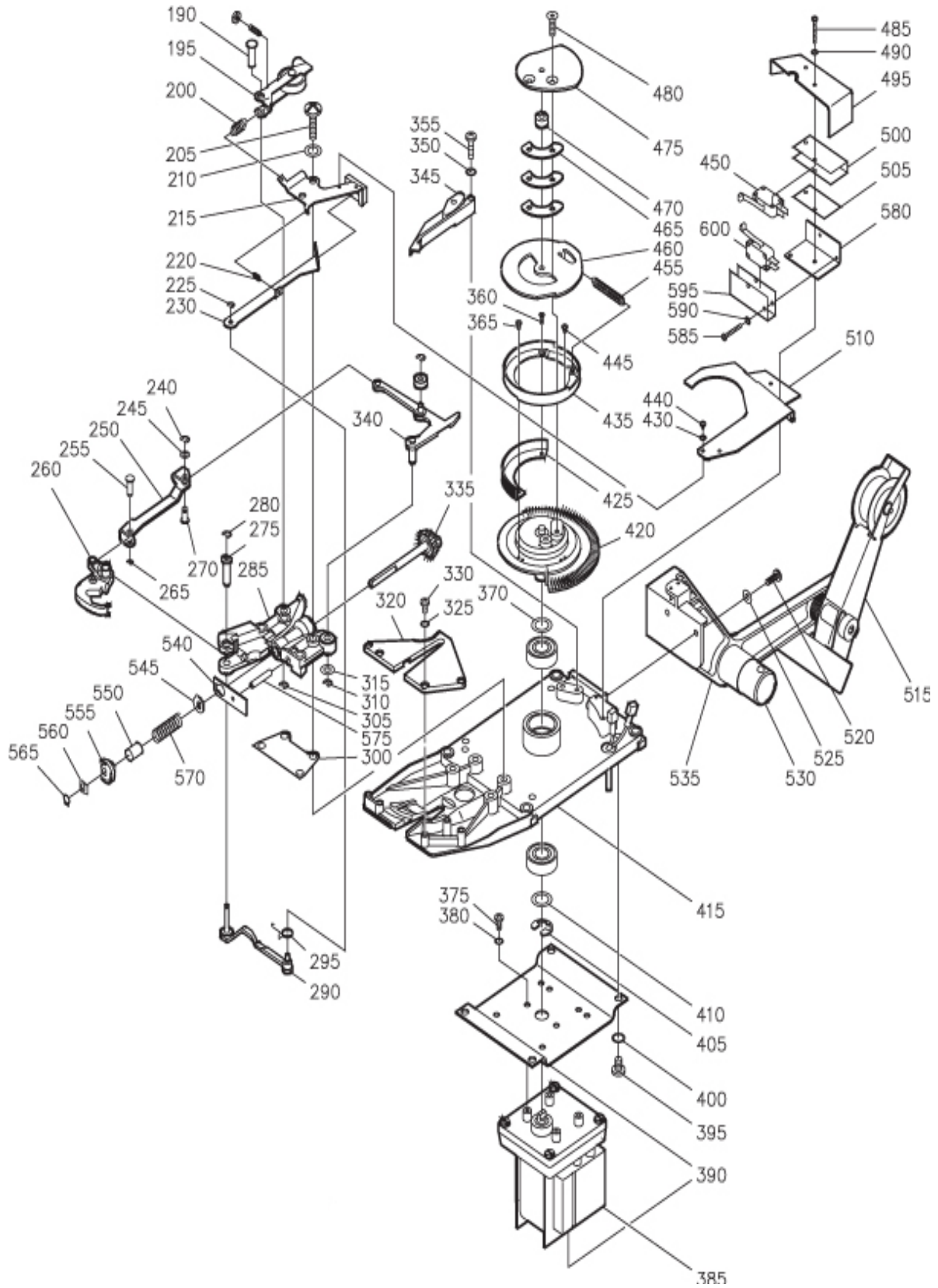

PLAS-TIES



TOLL-FREE: (800) 854-0137

PHONE: (714) 542-4487

FAX: (714) 972-2978

Email: info@plasties.com

Website: www.plasties.com

14272 Chambers Road Tustin, CA 92780